



Mr Andrew Ponsford
Principal

It is hard to believe ... but 35% of the 2019 school year is over for our Unit 3/4 students and Term 1 is almost at an end.

We spend so much time 'just keeping up' with the pace of life ... I wish everyone during the upcoming break:

- Time with family and friends
- Time to be still and take stock
- Time to just be
- Time to try something different
- Time to reflect and prepare

Congratulations to the Junior School community - Pyjama Day

So much fun, laughter and togetherness was generated this morning at the Pyjama Day – the joy was uplifting and provided a most suitable final week activity prior to the holiday break. Special thanks to the Junior School team and the many, many parents who supported a most successful and rewarding event for our students.

Congratulations

Our congratulations go to two of our students who will be busy over the school holidays.

Veronica Kaszkiel

Veronica has been accepted into the Royal Ballet Spring Intensive Program / audition in Hong Kong during the second half of April.

The Royal Ballet School is one of the top three centres for classical ballet training. The Spring Intensive Program allows dancers to experience a week long intensive training to determine their suitability for full time vocational training at White Lodge in London. The students will receive coaching and guidance from faculty members of the Royal Ballet School and the Royal Ballet Company.



Under the guidance of Shirley Rogers of the Shirley Rogers Academy of Dancing, Veronica has been accepted into the Spring Intensive Program being held in Hong Kong this year. In the past, the Royal Ballet School has received more than 2500 applicants where only some 270 has been accepted into the program.

Kayla Jones

Kayla has recently qualified and will be completing at the National Age Swimming Championships in Adelaide during the second week of the holidays. This is Kayla's first time at the National Championships and she will be competing in the 400m Individual Medley event.

ANZAC Day Dawn Service

Southern Cross Grammar will be represented at this year's ANZAC Day Dawn Service in Caroline Springs and our Year 6 students will be in attendance at the official Canberra Dawn Service.



Mrs Julie Baud
Deputy Principal
Head of Teaching and Learning (F – 12)

The Term 1 Progress Reports will be ready for collection from the Junior School Hub after school tomorrow. The letter accompanying these reports provides the below explanation. As the first formal report for the year, this report focuses on student growth rather than achievement. For each Learning Area, teachers have reported on students':

Knowledge and Understanding	application of the knowledge acquired and the level of understanding of the course content
Skill Development	the acquisition of subject-based skills
Readiness for Learning	homework completion, work ethic, the level of engagement, behaviour and organisation, resilience and positive mindset
Social Behaviours	interaction with peers/teachers, aptitude to work independently, general attitude, whether students are respectful and responsible

Teachers have articulated the growth each individual student has made in Term 1. Therefore, if a student has maintained their work habits since the commencement of the year, they would be listed



as Medium (M), whereby if a student has shown an improvement in these work / learning habits, they would be listed as High (H) or Very High (VH), depending on the improvements evidenced to teachers.

The next opportunity to receive feedback on student learning will be the Student Progress Interviews scheduled for the third week of Term 2.

The end of term is always a time for reflection on the weeks that have passed. A time to ask ourselves if we have made the most of our opportunities, if we really are serious about wanting to achieve our best, if we have used our learning time in class productively and if we have implemented an effective, ongoing revision program. If the answer to any of these questions is "No" it is maybe an appropriate time to reconsider our approach.

I am mindful of the mid-year exams commencing a few weeks into Term 2 as well as the importance of taking some time out to have a break over the next couple of weeks. A balanced approach is important. I would therefore encourage our senior students to have a break, but also spend time revising and reviewing the work covered in each subject during the term. This is important as the first few weeks of next term will pass and exams will be upon us very quickly.

Ms Louisa Rennie
Deputy Principal
Head of Senior School (10-12)

Electro Technology Studies at Victoria University

My name is Ben Klobas, I am currently in Year 11 and I have been attending SCG since Year 7. This year I commenced a Certificate II in Electrotechnology Studies at Victoria University. This course is very different to normal school, it includes all different types of hands on work for example Cutting Metal and Welding. This course fits in well with my school timetable, enabling me to have study sessions with my teachers to catch up on work that I may have missed while I am at the Course. This Certificate allows me to get an apprenticeship in Electrotechnology Studies and this will support me to achieve my goal to become an electrician. I would like to thank Ms Gowdy for guiding me into this career path and enabling ways for me to get there.

Ben Klobas Year 11



Term 2 Student Progress Interviews

As a school, we look forward to meeting with parents and students in Week 3 of next term for our customary Student Progress Interviews. Please accept the information below as advance notice so as to assist you to put measures in place to be available to meet with your child's teachers and gain insight into your child's progress and achievement.

Interviews provide opportunity for three-way conversation, an occasion for student reflection and for students, parents and teachers to work together to ensure our students are supported to achieve the best possible learning and personal development outcomes. All students are encouraged to attend interviews with their parents. Students attending the interviews must be in full school uniform. Dismissal time for students on Monday 6 May is per the normal times, 3.05pm in the Middle and Senior School and 3.10pm in the Junior School. Wednesday 8 May is a non-teaching day for F – Y11. All Unit 3/4 classes will continue as per the Daily Schedule on Wednesday 8 May.

Further details, including access to the booking site will be provided in Week 1 of next term. Interviews will be conducted:

- 3.30pm – 8.30pm on Monday 6 May and 8.30am – 8.00pm on Wednesday 8 May 2019
- in the Junior, Middle and Senior School buildings
- with Homeroom teachers from F – Y6
- with Subject teachers from Y7 – Y12.

Senior School Formal Dinner "Winter Wonderland" Friday 24 May 2019



The Senior School Student Representative Council (SRC) are excited to announce the details of our 2019 Senior School Formal Dinner, to be hosted on Friday 24 May 2019, from 7.00pm – 12.00 midnight. The Formal Dinner is a way of recognising our senior students as young adults and providing them an opportunity to enjoy one another's company in a formal setting. This calls on them to draw on their skills



to act and interact in ways that are appropriate to the occasion. All Senior School students are expected to attend school on the morning on Friday 24 May 2019. Those students studying a Unit 3/4 subject will be sitting a practice GAT (General Achievement Test) from 9.45am – 12.45pm. Following this, all Senior School students will be dismissed at 12.50pm.

The Formal Dinner is not a compulsory event, however all Southern Cross Grammar students from Year 10, Year 11 and Year 12 are welcome to attend. All Senior School students will be dismissed from school at 12.50pm to provide them with time to get ready for the Formal Dinner. Students have been briefed at school and parents will receive an information brochure via email.

Uniform in Term 2

A reminder to all students to transition to the Winter Uniform for Term 2.

Driver Education 20-22 May

The Driver Education Program is fast approaching and this year we have two groups participating in the 2-day program. The program will be held at The Charlton Traffic Safety Education Centre which is equipped with a track that is 1.7km in length, 700m of which is a sealed road. The remainder of the track is gravel. It features operating traffic lights, a pedestrian crossing, hill crest, roundabout and parking bays. The program caters for Pre-Learner drivers and Learner drivers and offers a blend of theory and practice. It is a time for learning, gaining valuable skills and developing positive peer relationships. Theoretical learning is a key component of the program, including a focus on attitude to driving, planning, highway and freeway driving, road toll statistics, steering and car control, traffic rules, regulations and signs, lane positioning, U turns and 3 point turns, alcohol and drugs, overtaking and cornering. A number of 'in-car / practical' skills are addressed as part of the program, including; steering, braking, road position, left and right turn, gear change, U turns, reversing, roundabouts, angle parking, hill starting, overtaking, cornering lines, parallel parking, 3 point turns and negotiating traffic lights to name a few. A Theoretical and Practical Test (similar to the L's theory test) is held on the second day. Good luck to all students involved in Term 2.

Term 1 Student Progress Reports

As is customary, parents are able to collect Student Progress Reports from Reception, from 3.15pm on Friday afternoon. The Office will also be open from 9.00am – 4.00pm during the school holidays for the

collection of reports.

In closing, our Senior School students have much to be proud of this term. How fortunate I have been to bear witness to many students facing and conquering personal challenges and striving to achieve their best. I hope that all Senior School students take the opportunity to rest and relax during the break, and find some time for focus and revision of their learning, in order to start the term strong. Best wishes to all families for the Easter season.

Ms Romina Pimpini Head of Junior School (F – 4)

As Term 1 2019 comes to a close,
We in the Junior School don't like to 'doze'.
So we donned our pyjamas for a very fun day,
And raised some money for RCH along the way!

The term has been fruitful,
filled with learning and fun.
For students, parents and teachers too,
We've included everyone.

We have enjoyed sport and incursions,
Pos Ed, Language, Music and Art.
Our learning has come a long way,
And this is just the start.

For term 2 is upon us – winter uniform we will wear,
We'll achieve our goals and aim really high,
Doing our best if we dare!

Be sure to enjoy the term break,
With your family and your friends.
Until we return on Tuesday April 23
To do it all over again!

Pyjama Day and Open Classrooms a Junior School hit!

Today we opened our classroom doors and our hearts in the Junior School.

Classrooms were open for family members to visit and share in the recent learning of our Junior School students. Many proud parents, grandparents and teachers discussed what has been a successful term, both in the classroom and beyond, through the social and emotional development of our youngest SCG family members.



Students and Staff wore their pyjamas today to raise money for the Royal Children’s Hospital Good Friday Appeal. Just by donating a gold coin across F-4, we were able to raise \$607.00 for this very worthy cause.

A huge thanks to all our Portfolio Captains for helping with money counting – a super doper Maths lesson for sure.



Foundation Breakfast

The start of the day was a buzz for our Foundation Classes of 2019, as they enjoyed a breakfast with their teachers and parents.

This, the first in the students’ experience in our Camps program, we believe will help them develop their independence at school and in life.

Many thanks to all our volunteer Brekkie Helper parents





School Photo Day 2019

Friday 3 May is our School Photos Day.



By now, your child/ren should have brought home their personalised Photo Order envelopes.

All students will be photographed, both individually and as a member of their Homeroom. Given this, it is expected that students are dressed proudly in their full formal winter uniform on this occasion.

Please mark this important date in your calendar and diary so that everyone is best-prepared.

Junior School Assembly this week

Join us to celebrate the end of term at our Junior School Assembly on Friday 5 April commencing at 8.45am.

Chess in the Junior School

Chess

Our chess program develops concentration, visualisation, resilience and problem-solving skills. In each lesson children learn a new strategy, tactic, moves or about a famous player or event before playing games. Playing the game of chess provides a challenge in a positive environment that fosters good sportsmanship and self-confidence.



From Term 2, students of the Junior School are invited to join in Chess workshops after school on Monday afternoons.

For costings and registration, click [here](#).



It's coming in Term 2...



Ms Kylie Lidgerwood Art Teacher (5-12)

Using a Design Brief students in Year 10 Visual Communication and Design designed Cubby Houses for the International Flower and Garden Show. Whilst creating their designs, students followed the design process and manually drew scaled floorplans and elevation drawings of their dream Cubby House. Attached to this newsletter are some examples of their final presentations.

M Lincoln Busby Drama Teacher

School Production

The story of Voltaire's Candide, as adapted in two hilarious hours by Southern Cross Grammar. Candide, the unlucky innocent, is lead through a series of outlandish, side-splitting misadventures that span nine countries, in order to be reunited with his childhood love.

Along his journey, he encounters plane crashes, war, passion, riches beyond the comprehension of mortal man, revolution, slave traders, and monkeys- lots of monkeys. Throughout his escapades, he is forced to question his optimistic outlook: is life a cruel or kind expedition? In the end, optimism and good prevail.

[Click here](#) to secure tickets.

Four performances including one matinee.

Ms Jade Panozzo Head of Sport (3 - 6)

Well Done to the six Junior and Middle school students who competed in the highly competitive Western Metropolitan Region Swimming Championships yesterday in Geelong.



Please see below for the results achieved on the day:

- Elisa Vigniuoli- A blistering swim of 35.41 seconds for 50m Freestyle earned Elisa an overall 2nd position out of seventeen competitors. She was only one finish place away from making the state team!
- Taylah Roberts- Competed in both the 50m Backstroke and the 50m Freestyle, bettering both of her seed times.
- Xavier Walker- Participated in arguably the most challenging event on the program, the 50m Butterfly, where he demonstrated a positive attitude and quiet competitiveness throughout the race. Well Done Xavier!
- Elisa Vigniuoli, Megan Scott, Ashton Dessman and Ruby Spiteri- had to wait until the fourth last event of the program before getting their time to shine. They represented SCG in the Freestyle relay where they came 6th overall and beat their heat time by a second.

All members of the team are to be commended on their attitude throughout yesterday's event as well as the three swimming events preceding this one.



Ms Sarah Payton

Parents and Friends Association Chair

Throughout Term 1, the PFA have been busy setting up the events calendar, planning upcoming activities and establishing the PFA committee for 2019.

Highlights from Term 1 include;

- Lego Movie- a great social event for the school community
- Parents Disco Trivia Night- allowed parents to let their hair down

(or put a wig on), meet other parents, take home great prizes and even sing and shake their groove things whilst contributing to PFA fundraising!



Parents, friends and Staff joined in the fun at our Disco Trivia Night

Upcoming Term 2 events to be on the look out for;

- Avengers Movie (Thursday 25 April) – limited tickets still available. (DON'T MISS OUT!)
- Mother's Day Stall (Friday 10 May) – a school and student favourite encouraging the students to increase their independence and confidence in choosing gifts and handling money
- Toy Story 4 Movie (Sunday 23 June) – The long awaited next instalment for Buzz & Woody!
- The "New to You" uniform shop will continue on Friday afternoons from 2.30pm

Join us at the next PFA meeting
Wednesday 1 May, 7.00pm in the Junior School Hub

If you can share just one hour of your time to assist with any of these events, please contact the pfa@scg.vic.edu.au to register as a volunteer and have a current Working With Children's Check recorded with Reception.

New to you uniform shop

Term 2 is the start of winter uniform. We have in stock preloved;

- Trousers from \$17
- Winter skirts \$67
- Old logo Woollen jumpers and vests reduced to \$15
- Old logo long sleeve shirts reduced to \$5
- A Limited number of tunics available
- Elastic and full length ties preloved \$11 and brand new \$22

We are in need of girls tunics and boys blazers. If you have any you would like to list for sale, please drop these off at reception with your contact details.



Introducing Pathways Staff

Ms Sophie Macreadie - Pathways Coordinator

As Pathways Coordinator, my role will be to provide advice and guidance to Senior School students about their tertiary options upon finishing their secondary education. I'm here to help students arm themselves with the knowledge of what is required to get into their desired course, where that course can lead them, as well as any secondary options to get to that destination should plan A be unsuccessful. I will also be assisting students with subject selection choices later in the year, conducting interviews and assisting students to understand what their choice might mean for them.

Ms Judith Gowdy - Vocational Education Co-ordinator

Essentially my role is to guide and support senior students as they consider vocational and alternative pathways to tertiary study. I will be providing information and advice to students and families regarding alternate pathways and supporting students through regular meetings and check ins. I will also be organising and implementing the Work Experience Program. If you are a parent or carer and are in a position to offer a placement to a work experience student, or you know someone who is, I would love to hear from you.

Both Pathways Co-ordinators are available to assist both students and parents in gathering information regarding different pathways, courses and any other career related queries. Please feel free to get in touch should you have any queries.

Upcoming Dates and Events

UCAT ANZ Test (formally UMAT)

The UCAT ANZ test has replaced UMAT (Undergraduate Medicine and Health Sciences Admission Test) for 2019. The UCAT ANZ test is a 2-hour, computer-based test, multiple choice test. Candidates will sit the test at Pearson VUE test centres located in Australia, New Zealand and some overseas centres.

Students who are planning to apply to Medicine, Dentistry and Health Science Courses commencing in 2020 at our Consortium Universities in Australia and New Zealand must sit the UCAT ANZ 2019 test in the month of July 2019- list of applicable courses is available [here](#). Registration and Booking are open now at the UCAT ANZ website and will close on 17 May 2019 at 11:59pm AEST (Australian Eastern

Standard Time). Late registrations or bookings will not be accepted after this deadline.

VCE Careers Expo

On 2 May, 2019, Year 12 students will be attending the VCE Careers Expo at the Caulfield Racecourse. This excursion will provide Year 12 students with the opportunity to meet with representatives from a wide range of organisations and ask questions and advice relating to career options as well as the VCE program.

Work Experience week:

A reminder that work experience is to be completed from the 18th-22nd November, it is compulsory for all Year 10 & 11 students. Work experience is a good way to sample career options, build confidence in one's capacity, develop life experience, extend one's professional network and exercise skills that are being developed through school. All students are encouraged to seek out their own work experience opportunity. It is important to try and secure work experience in an industry that you wish to explore as a career option. Many work experience placements come from people you already know. Alternatively, the Work Experience Directory lists 100s of opportunities, this is accessible [here](#). Work Experience Arrangement Forms can be collected from Ms Gowdy or accessed online via Careers on School box.

Resources

School Box

There is a "Careers" page on the Schoolbox dashboard. This is filled with lots of resources and information relating to Careers, including apprenticeship pathways, and Work Experience.

Study Work Grow

The Study Work Grow website provides a wealth of knowledge regarding scholarships, university open days and many other programs and opportunities. All students at Southern Cross Grammar are able to sign up as members. This will give them access to valuable information, including the weekly newsletters highlighting important dates and opportunities. The website can be accessed [here](#) (password is SCGRM19)

Victorian Tertiary Admissions Centre

The Victorian Tertiary Admissions Centre (VTAC) is the administrative body that processes applications for Universities in the state of Victo-



ria. All students and parents should familiarise themselves with this website as it contains important information regarding scholarships, course information from all Victorian universities and importantly, the entry requirements. Furthermore, all students have been advised to subscribe to the VTAC update to ensure important dates and information is received. VTAC can be accessed [here](#) (note: the link to subscribe to updates is in the bottom right).

Upcoming Open Days and Info Sessions

April

Australian Defence Force Information Session Tuesday April 9 | 18:00
| Melbourne, VIC
Find out more [here](#)

Australian College of Applied Psychology | Information Session Melbourne
Monday 29 April | 6.00pm | ACAP Melbourne Campus
Find out more and register [here](#)

May

Victoria University | Business Course Information Sessions
Thursday 9 May | 6.30pm- 7.30pm | Melbourne Campus
Find out more and register [here](#)

JCU | Careers in Health Webinar
Monday 13 May | 4.00pm- 5.00pm | Online
Register [here](#).

ACU | Melbourne Midyear Open Evening
Wednesday 15 May | ACU Melbourne Campus
Find out more [here](#)

Victoria University | Music Course Info Sessions
Thursday 16 May | 6.30pm- 7.30pm | Kindred Studios
Find out more and register [here](#)

Victoria University | Building & Engineering Course Info Sessions
Tuesday 21 May | 6.30pm- 7.30pm | Footscray Park Campus
Find out more and register [here](#)
Victoria University | Law, Criminology & Legal Services Course Info Sessions
Thursday 23 May | 6.30pm- 7.30pm | City Queen Campus
Find out more and register [here](#)

Victoria University | Education & Early Childhood Course Info Sessions
Tuesday 14 May | 6.30pm- 7.30pm | Footscray Park Campus

Find out more and register [here](#)

Victoria University | Health & Biomedicine Course Info Sessions
Thursday 30 May | 6.30pm- 7.30pm | St Albans Campus
Find out more and register [here](#)

June

Victoria University | Beauty & Dermal Science Course Info Sessions
Thursday 13 June | 6.30pm- 7.30pm | City Queen Campus
Find out more and register [here](#)

Victoria University | Sports & Exercise Science Course Info Sessions
Tuesday 4 June | 6.30pm- 7.30pm | Footscray Park Campus
Find out more and register [here](#)

Victoria University | Psychology & Social Work Course Info Sessions
Tuesday 28 May | 6.30pm- 7.30pm | Footscray Park Campus
Find out more and register [here](#)

Victoria University | Science & IT Course Info Sessions
Thursday 20 June | 6.30pm- 7.30pm | Footscray Park Campus
Find out more and register [here](#)

Victoria University | Tourism, Hospitality & Event Management Info Sessions
Tuesday 25 June | 6.30pm- 7.30pm | City Flinders Campus
Find out more and register [here](#)

Victoria University | Youth Work & Community Development Course Info Sessions
Tuesday 18 June | 6.30pm- 7.30pm | Footscray Park Campus
Find out more and register [here](#)

The above information has been taken from Study Work Grow, so sign up and explore the site for more information!

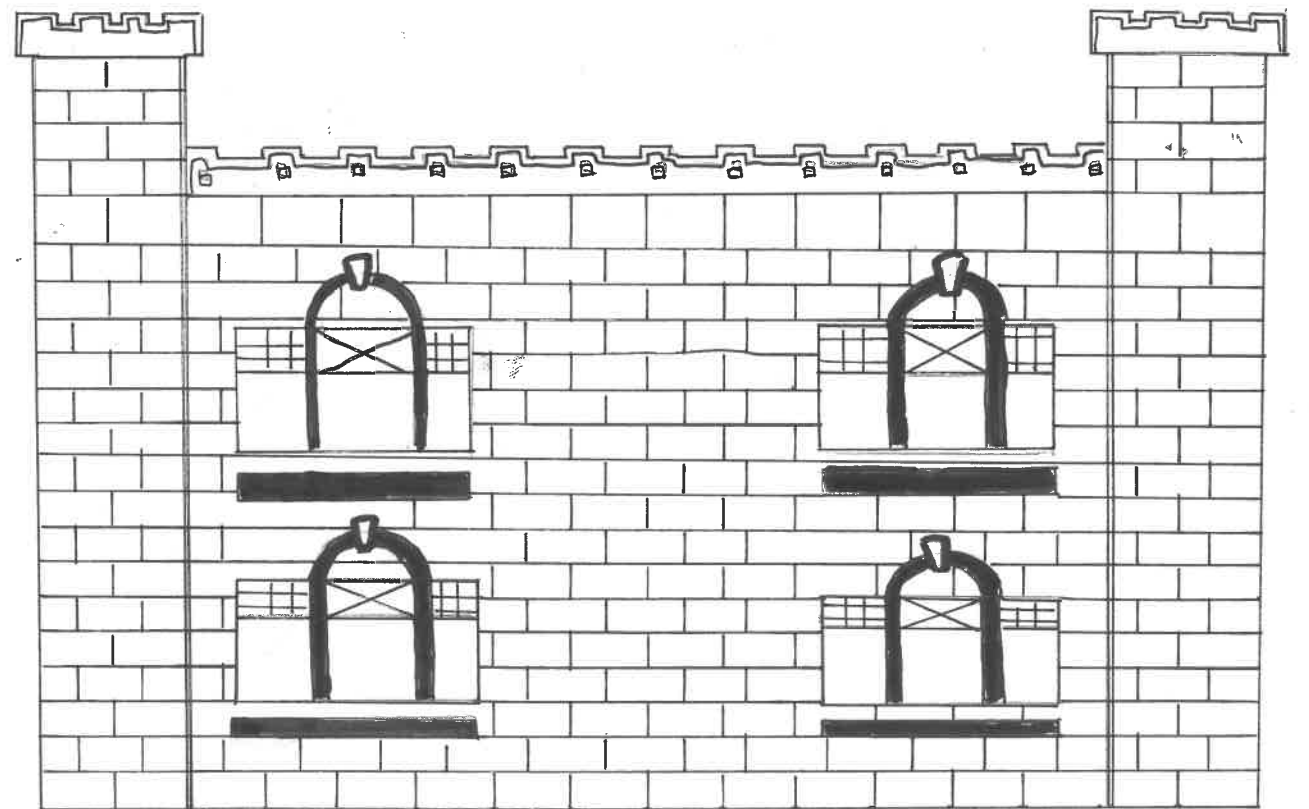
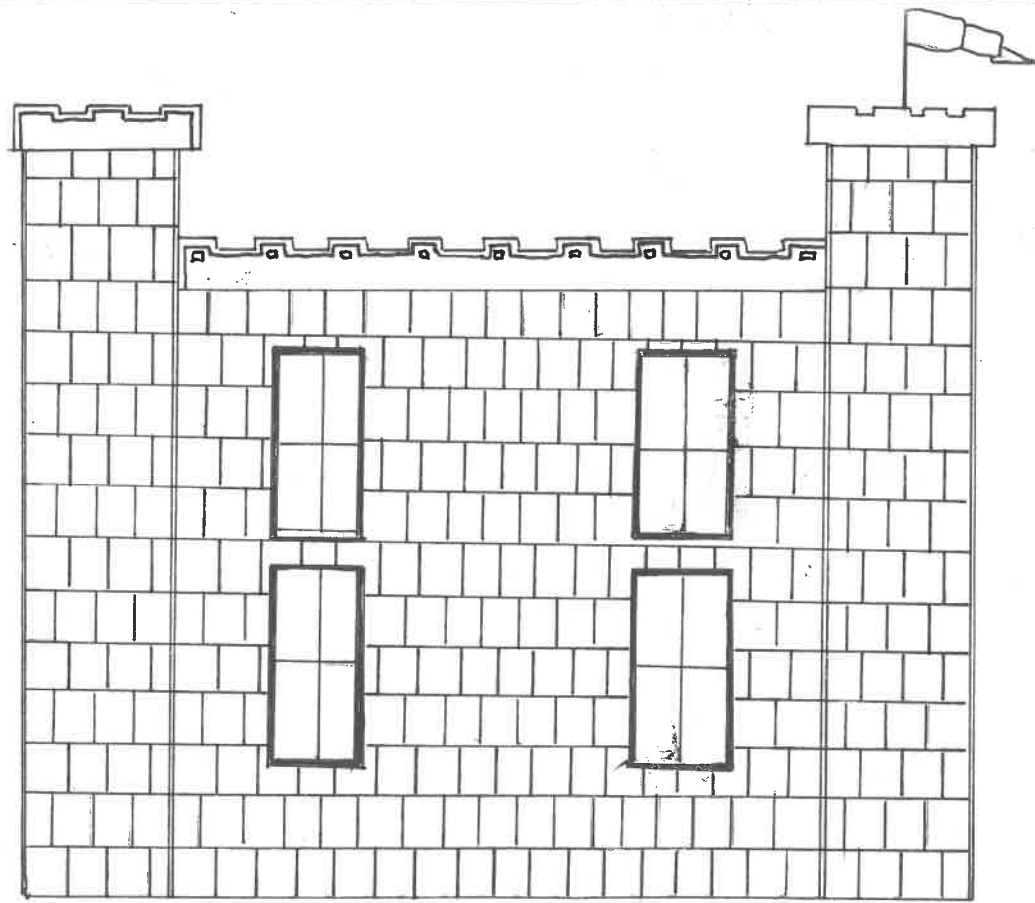
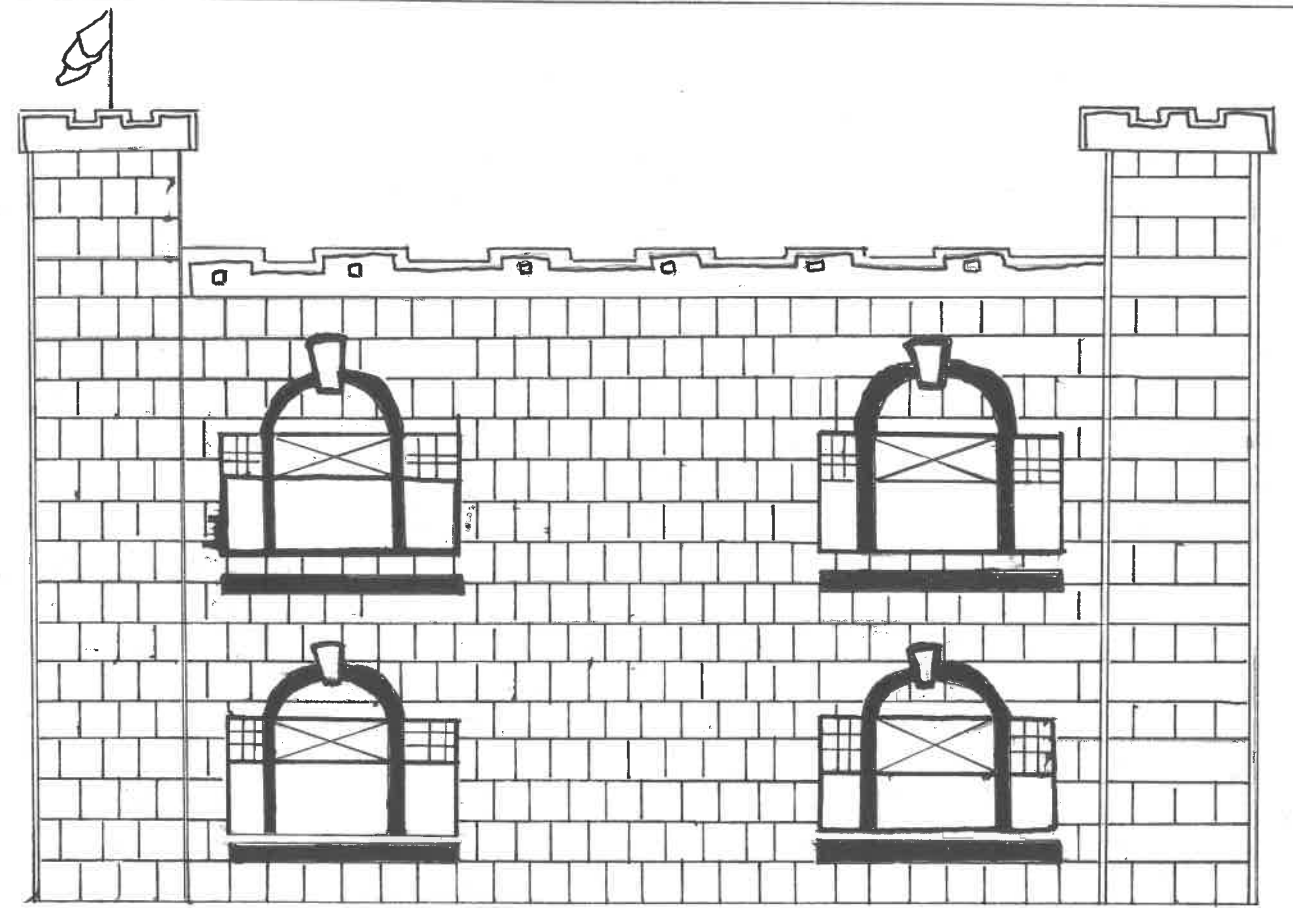
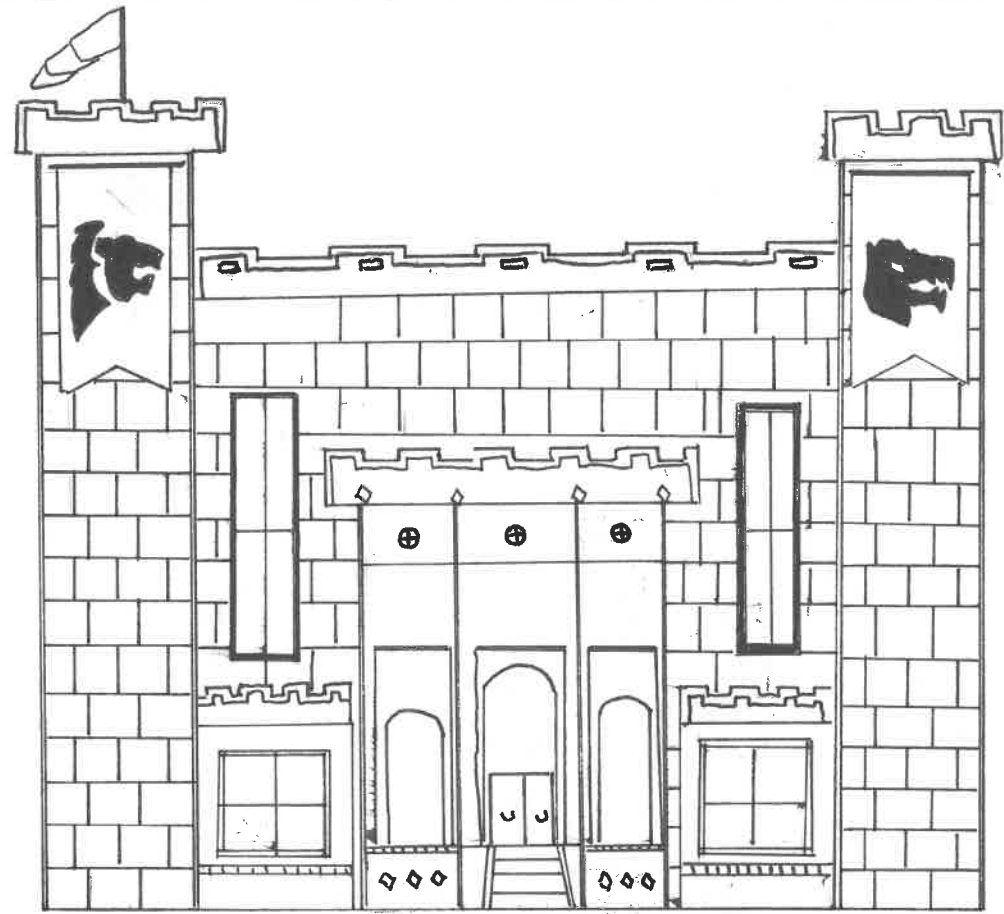

NAME: JOSHUA MACPHERSON

CLASS: 10-3

ELEVATION DRAWING

1st MARCH 2019

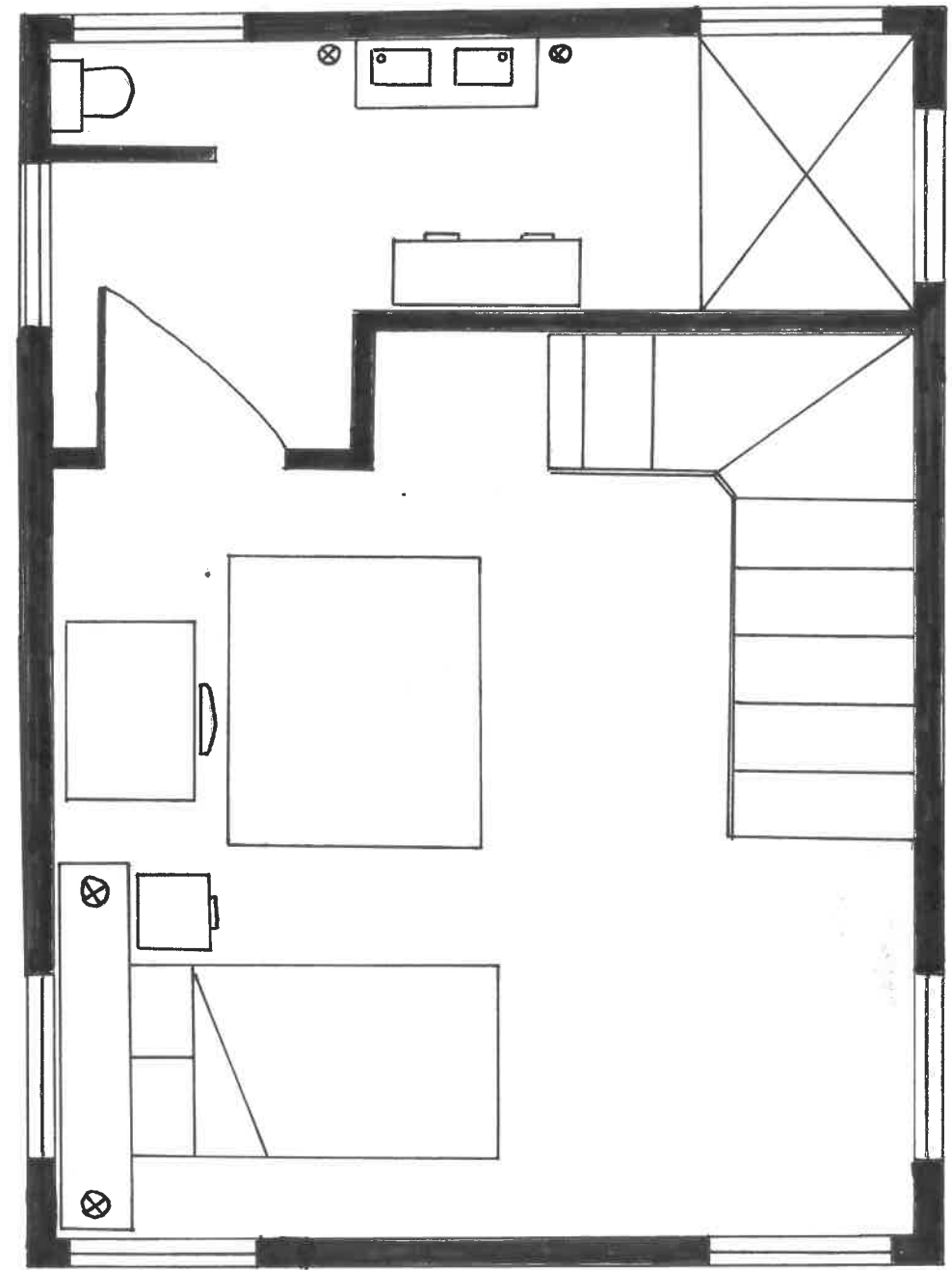
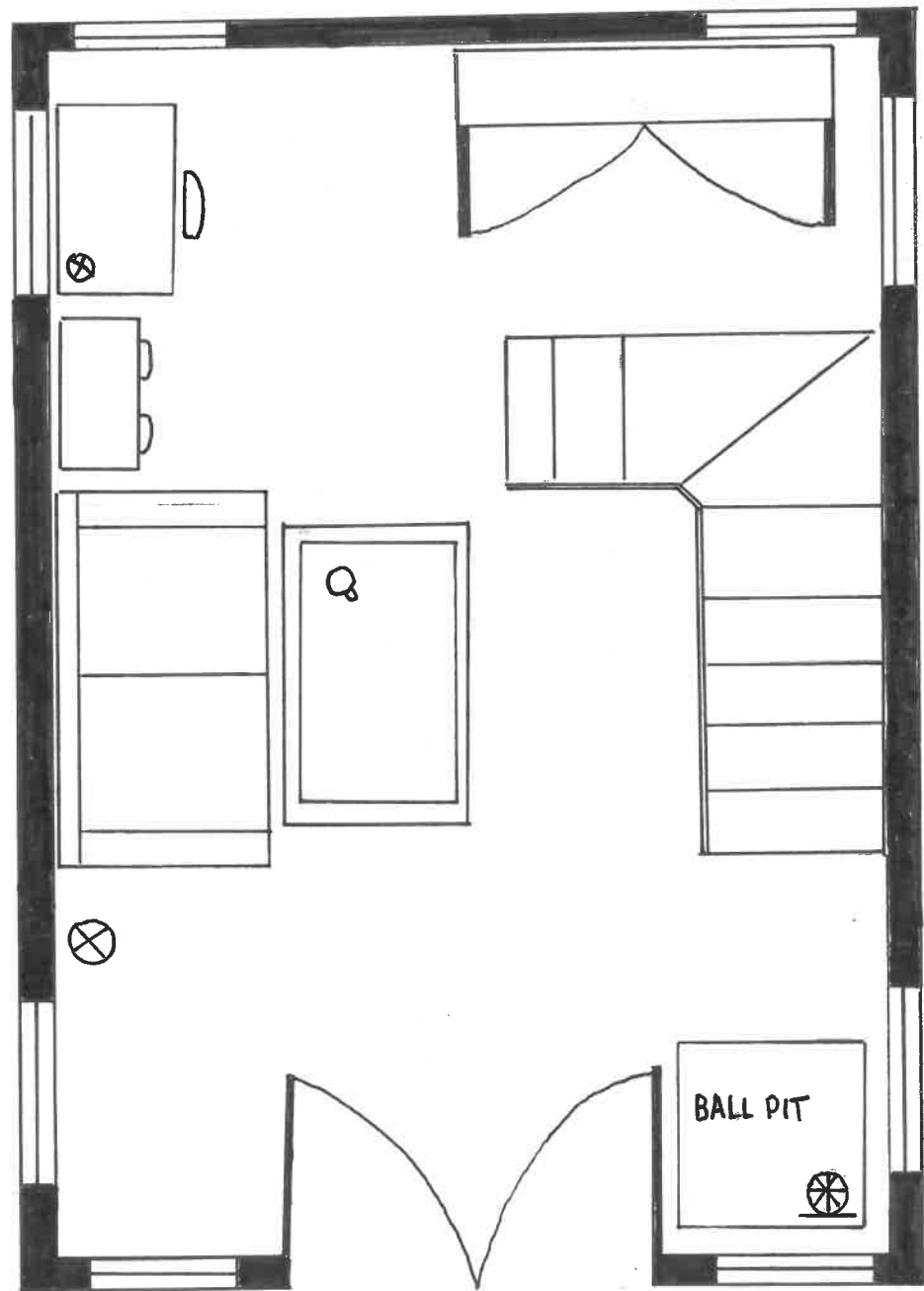

NAME: JOSHUA MACPHERSON

CLASS: 10-3

CUBBY HOUSE FLOOR PLAN

SCALE 1:20

15th FEBRUARY 2019

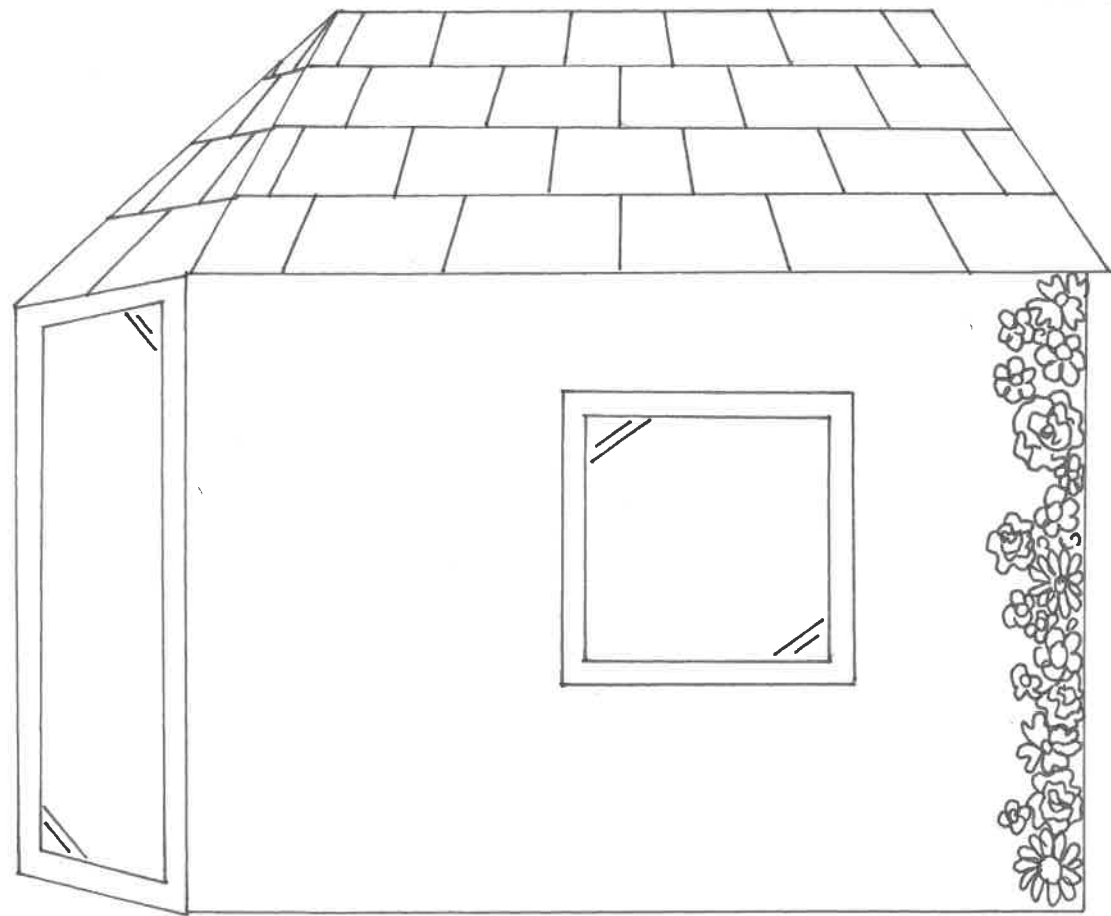

NORTH

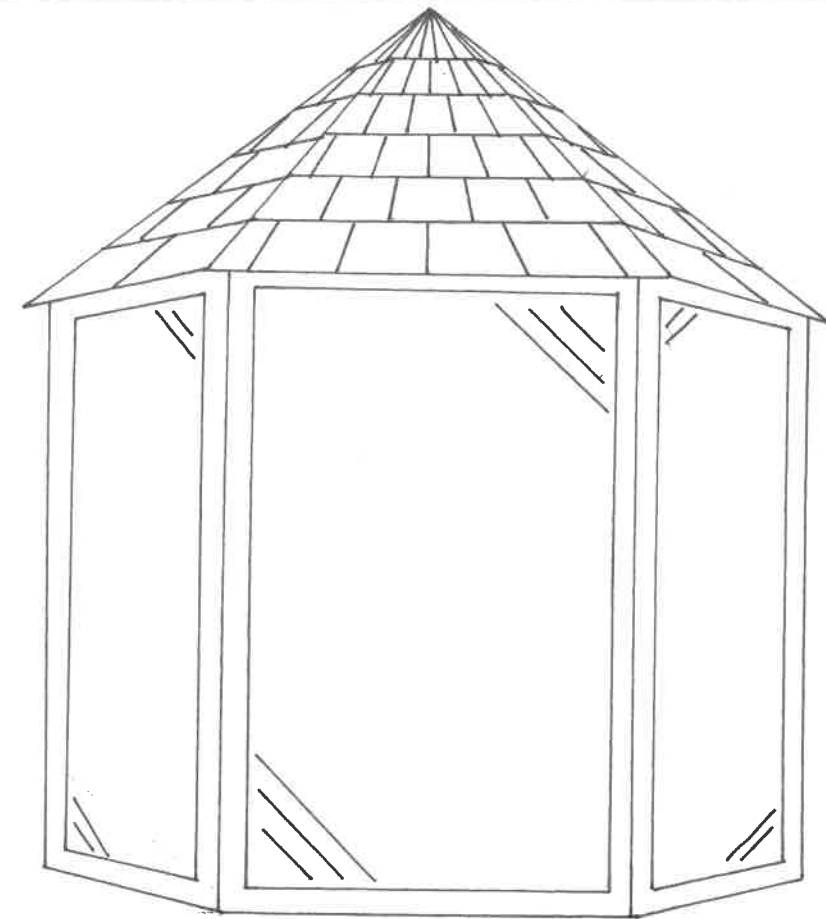

EAST

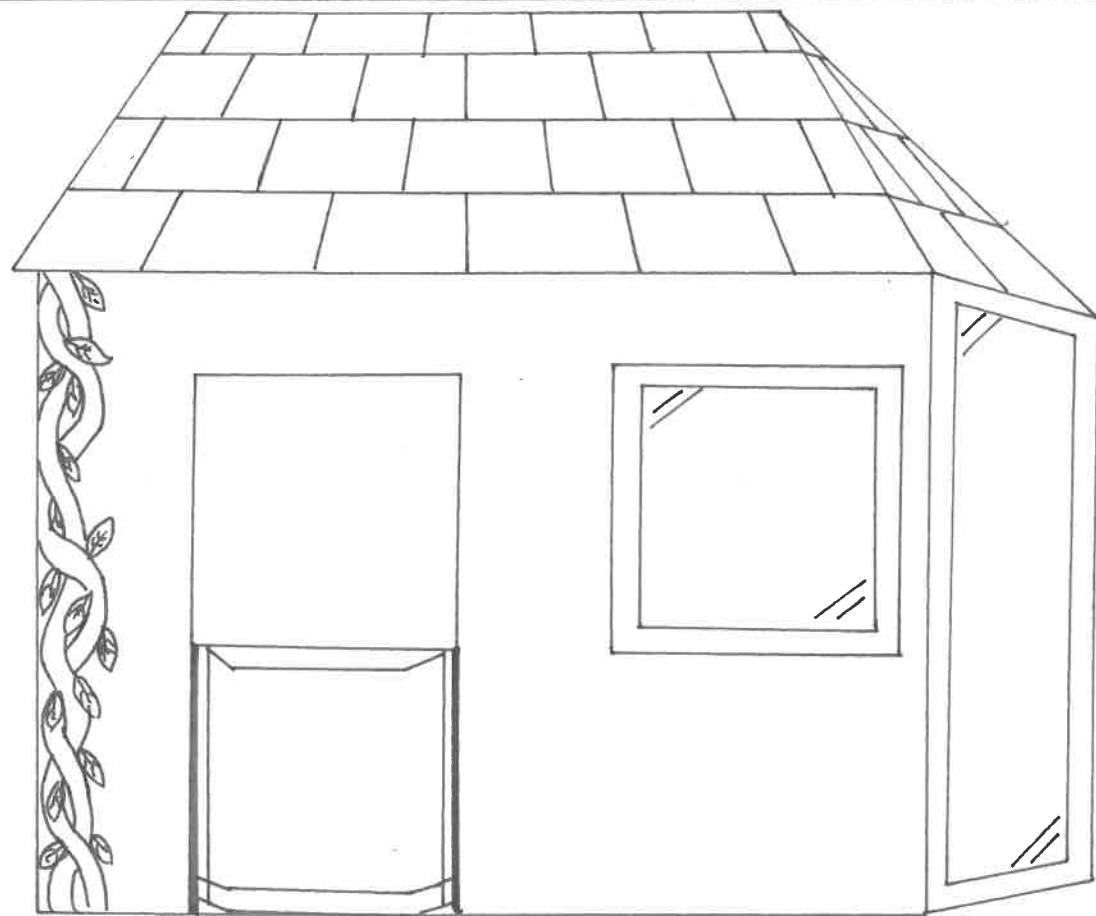

SOUTH

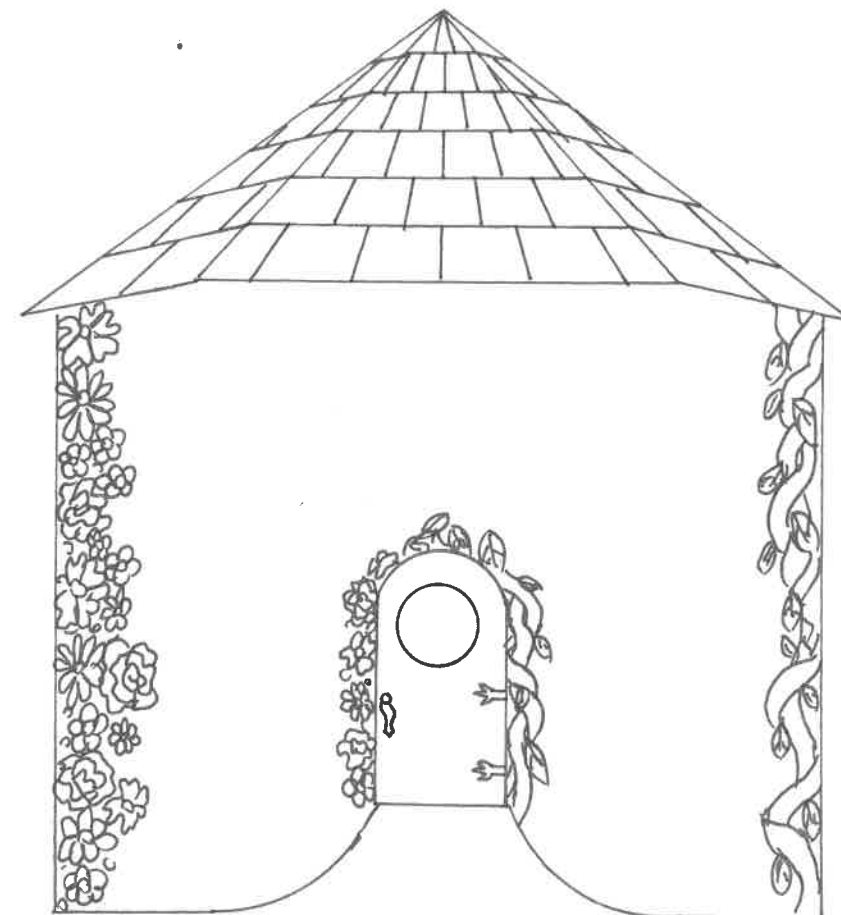

WEST

NAME KAYLA JONES CLASS:10.2 CUBBY HOUSE ELEVATIONS SCALE: 1:25 DATE: 1ST MARCH 2019

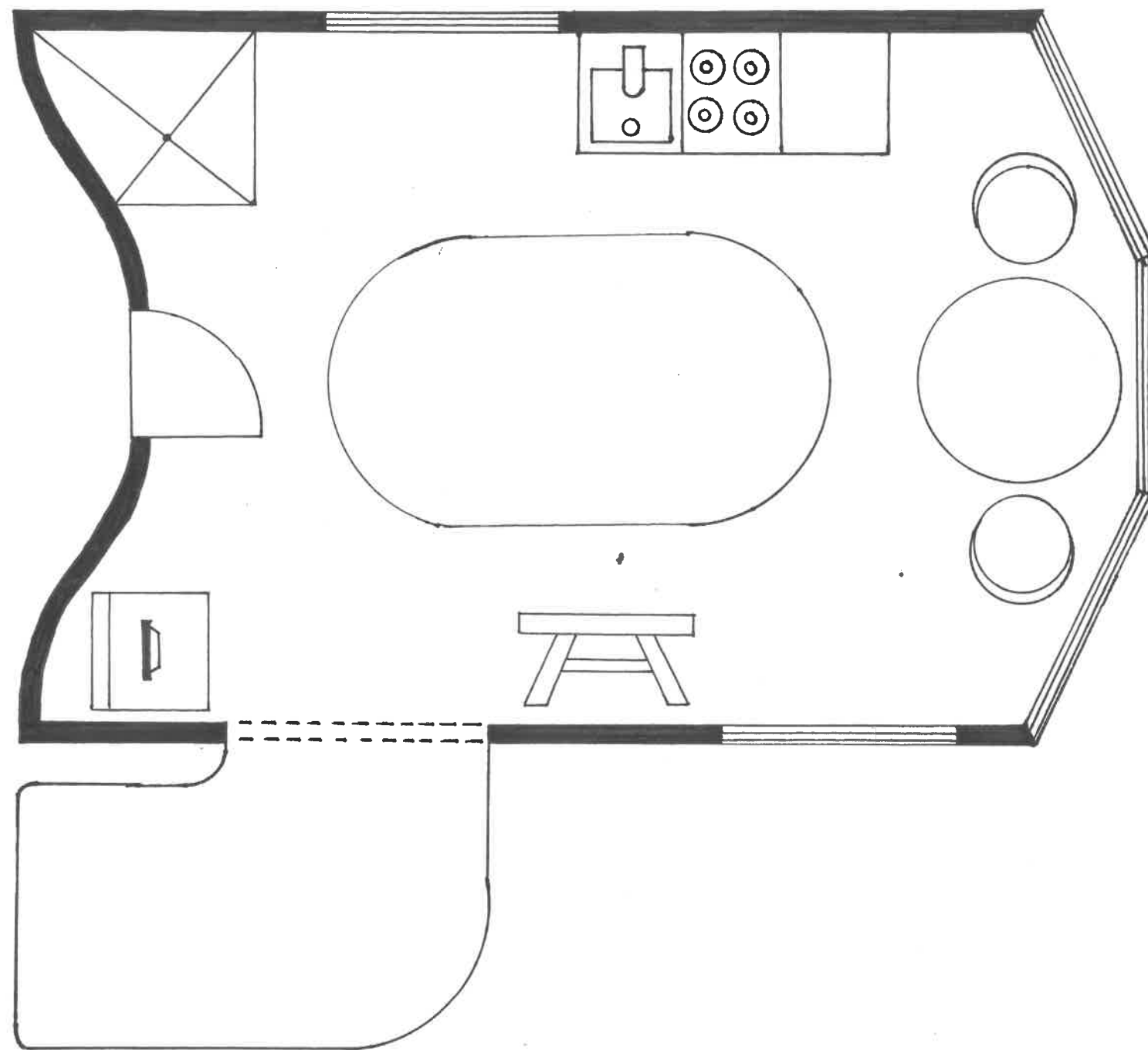

NAME: KAYLA JONES | CLASS: 10.2 | DRG: CUBBY HOUSE FLOORPLAN | SCALE: 1:20 | DATE: 14TH FEBRUARY 2019

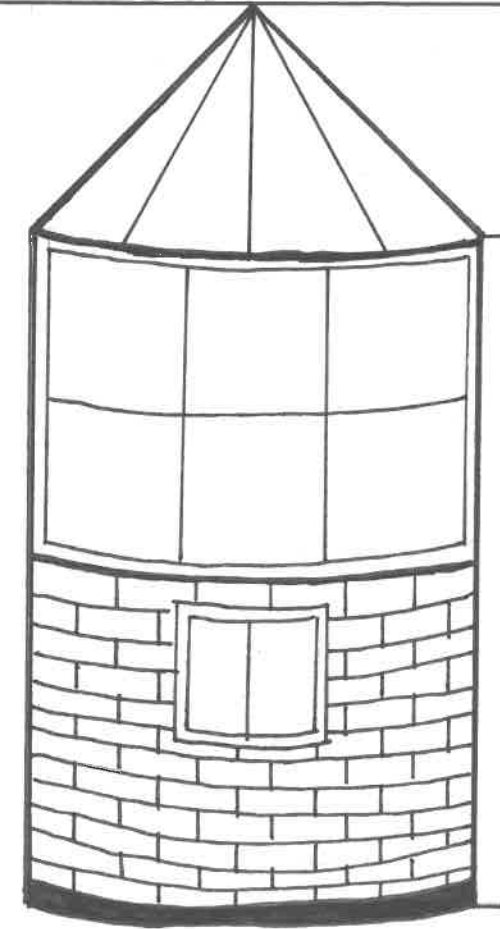
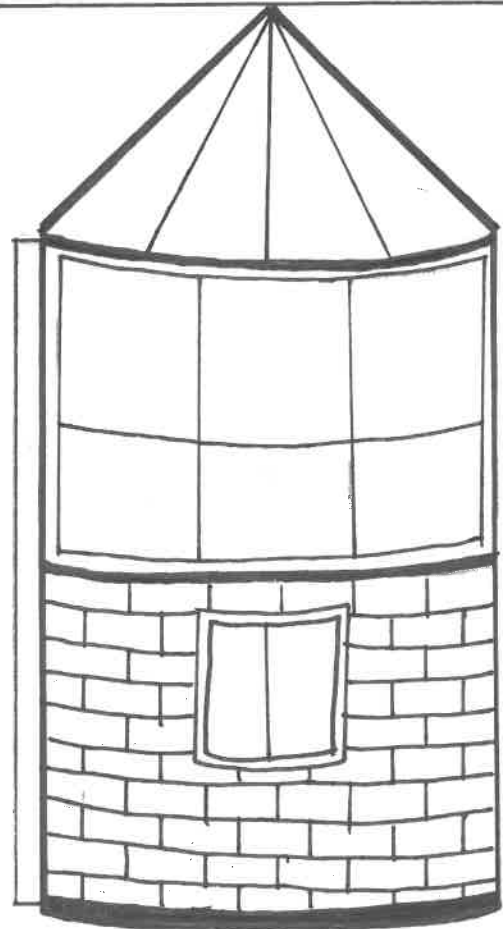
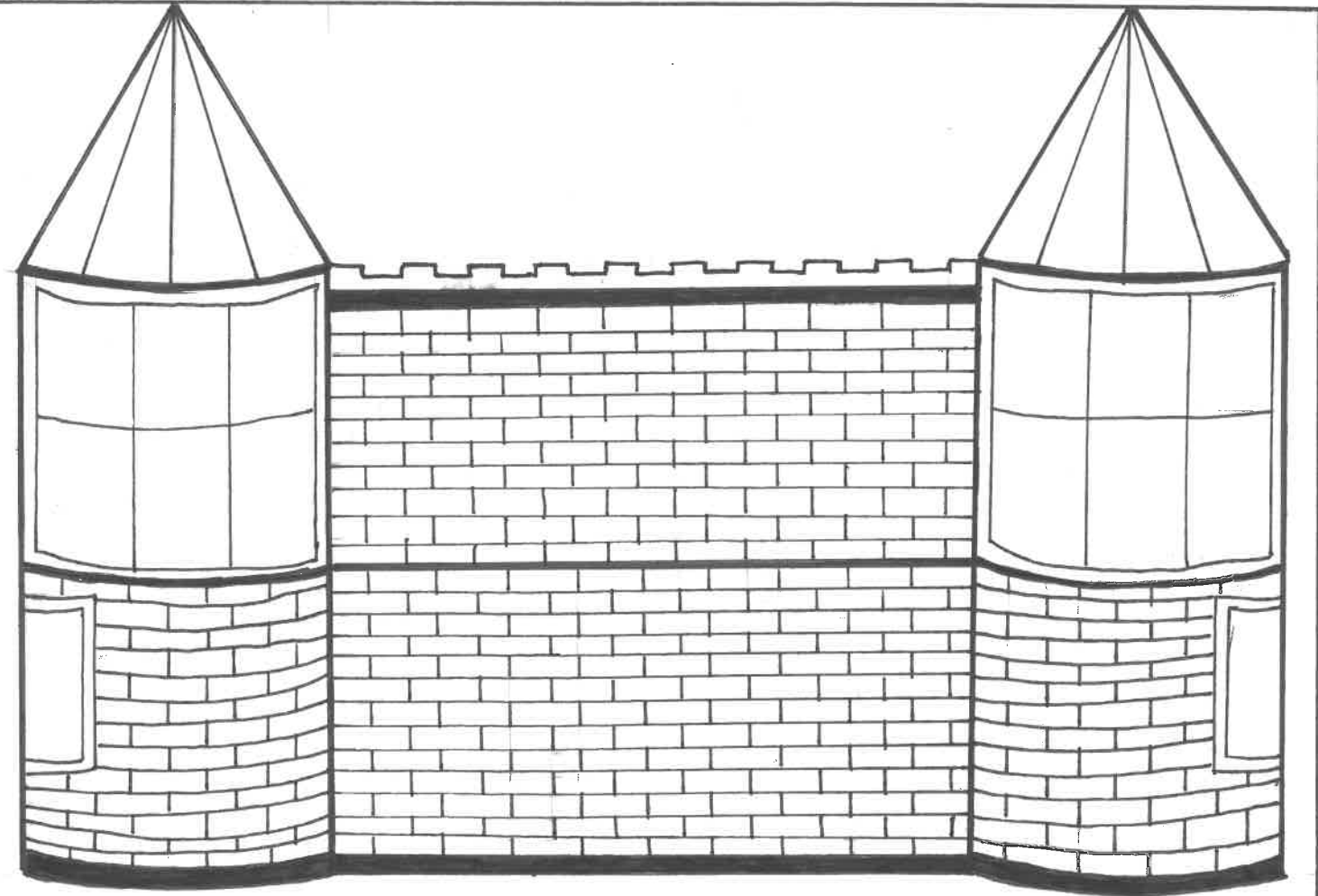
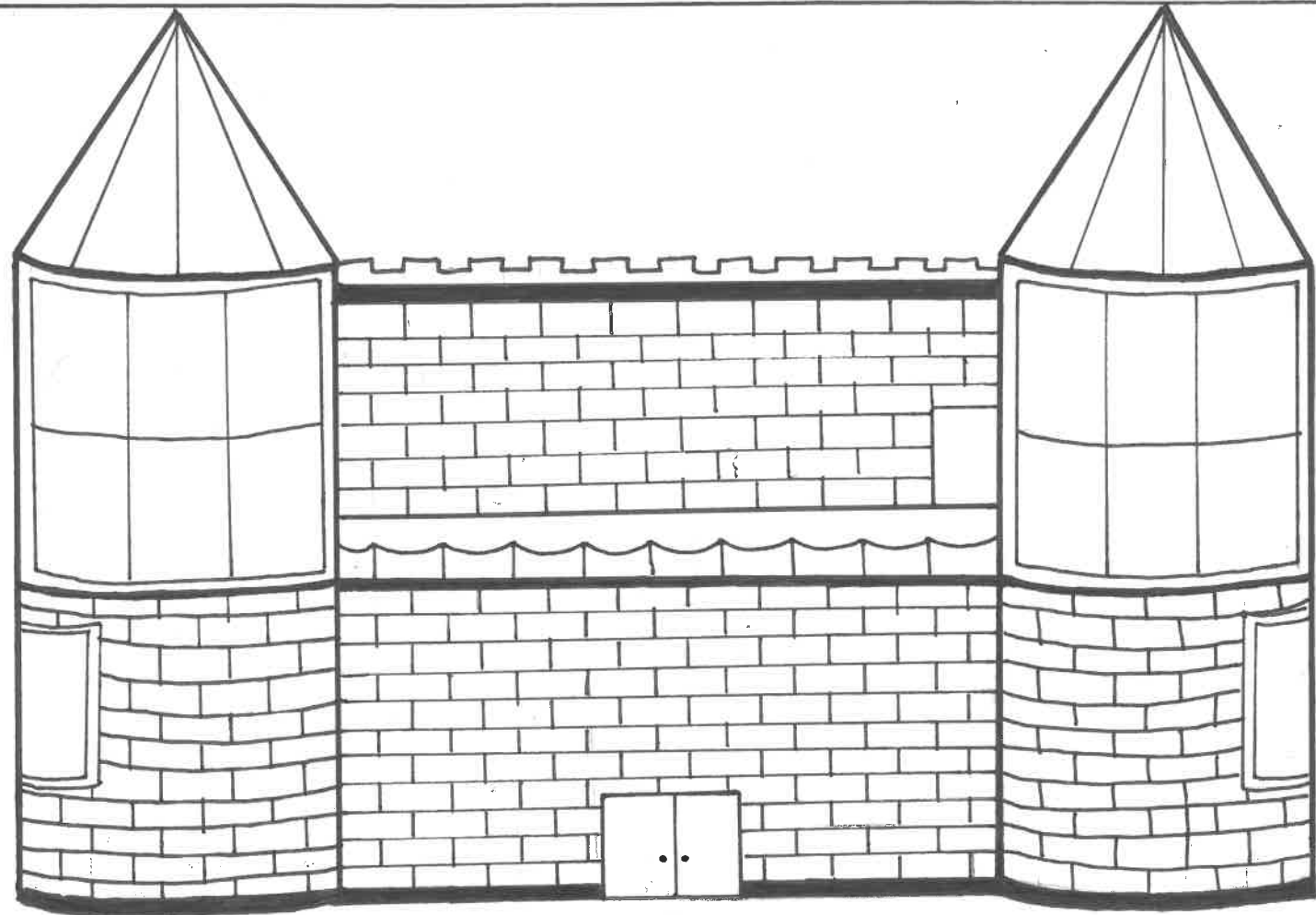

NAME : VAANE SINGH

CLASS : 10.3

CUBBY HOUSE ELEVATIONS

DATE : 1st MARCH 2019

SCALE : 1

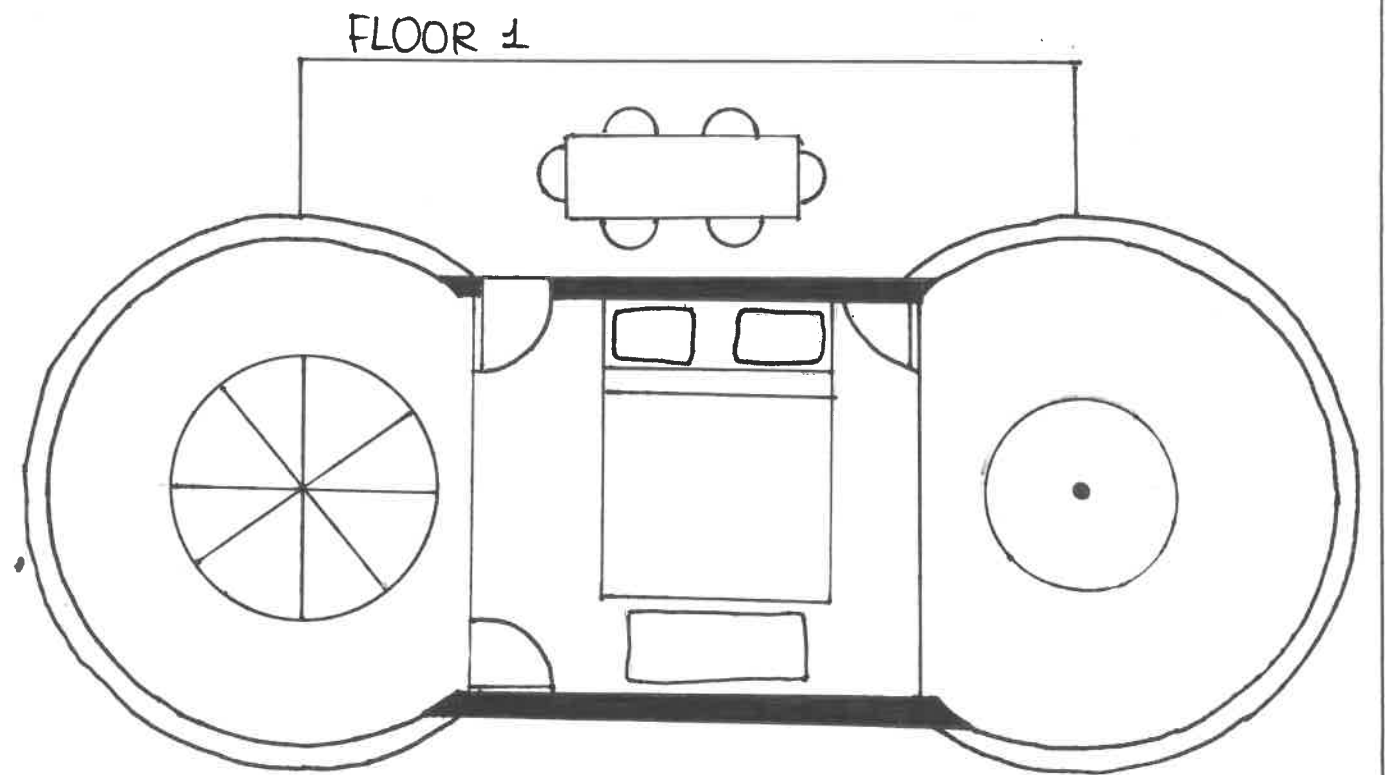
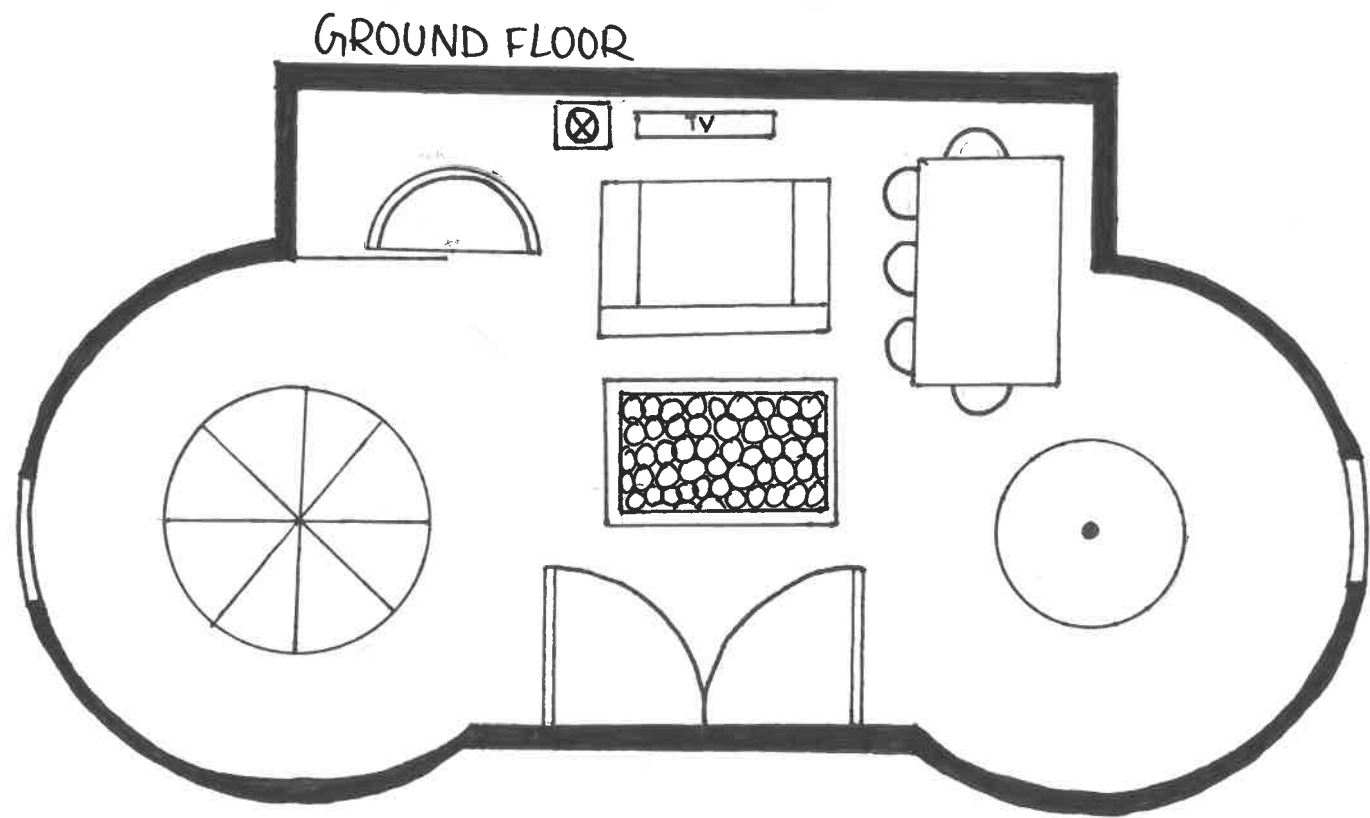

NAME: VAANEE SINGH

CLASS: 10.3

CUBBY HOUSE FLOOR PLAN

SCALE : 1:20

DATE: 15th FEB 2019